



Safeguard Systems

THE DAMPER SPECIALIST COMPANY



ALWAYS READ THIS DOCUMENT BEFORE INSTALLATION. PLEASE RETAIN FOR FUTURE REFERENCE.

This product forms part of a life safety system. Failure to correctly store, handle, install and maintain the product will directly put at risk the lives of the occupants and the fabric of the building.

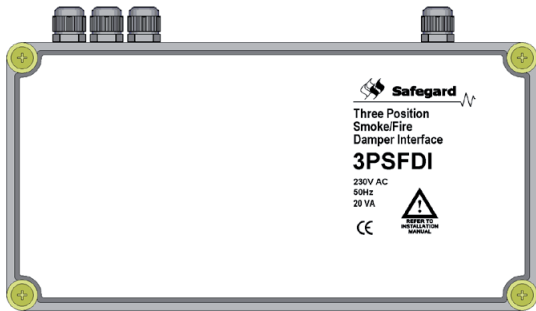

The Safeguard 3PSFDI provides a complete Lonworks® communication device to control a single 24V modulating actuator (spring-return or drive-open/drive-close) that incorporates two auxiliary switches.

Installation Instructions and Datasheet

Three Position Smoke Fire Damper Interface (230V)



Safeguard Systems

THE DAMPER SPECIALIST COMPANY

Dimensions and Mounting

The compact and robust design of the 3PSFDI enclosure allows the unit to be mounted to a duct, block wall or stud wall.

Ensure the unit is accessible for future maintenance purposes.

Please note:

- Unused cable entries should be sealed with blind washers.
- Do not drill the enclosure as this will affect its IP rating.

Mounting Diagram

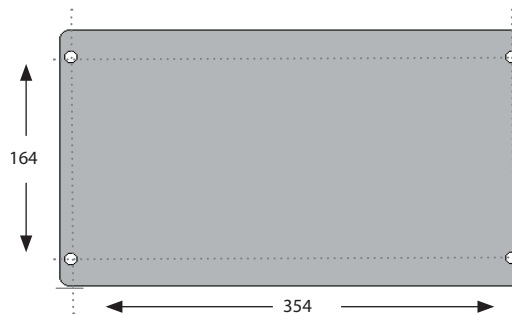
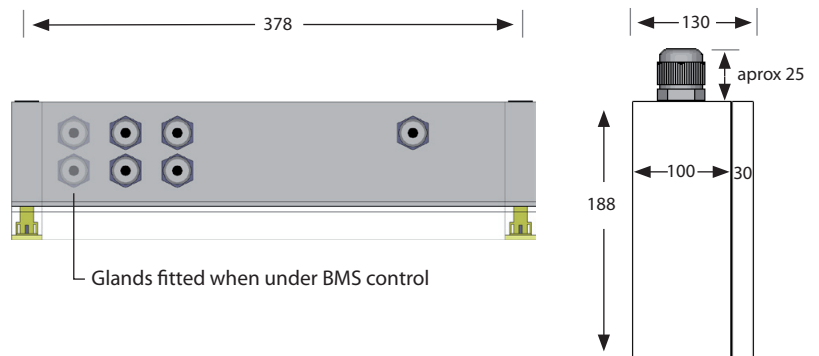

Four mounting holes $\text{\O} 6\text{mm}$ for mounting with suitable screws depending on whether mounting to a duct, block wall or stud wall.

Dimensions in mm.



Safeguard Systems

THE DAMPER SPECIALIST COMPANY

Preparation

- Only trained and qualified personnel should be allowed to install, replace or service this equipment. Installation should be in accordance with the relevant local safety standards.
- The connectors can accommodate cable diameters up to 2.5mm². It is recommended that all wires be crimped to ease installation and replacement of the product.
- The mains wiring should comply with IEC 60227 or IEC 60245.
- A switch or circuit breaker should be included as part of the installation.
- The switch or circuit breaker should meet the relevant requirements of IEC 60947-1 and IEC 60947-3.
- The switch or circuit breaker should be in close proximity to the equipment and be within easy reach of the operator.
- The switch or circuit breaker should be marked as the disconnecting device for the equipment and should disconnect both poles of the supply.
- The switch or circuit breaker should not interrupt the protected earth conductor.
- This equipment **MUST** be earthed.

Installation

1. Disconnect the local supply before commencing any work on this equipment.
2. Wire the incoming mains cable in accordance with the wiring diagram shown on page 4.
3. The mains cable should be fitted in such a manner that, should the cable be subject to strain, the earth wire would be the last wire to break loose.
4. The mains cable should be secured using the cable gland provided and tie wrapped to prevent slippage.
5. It is recommended that the network cables are not run alongside any high voltage or high frequency sources. Also, network cables must not be mixed on an individual network as they have very different electrical characteristics and could render the system unreliable.
6. Wire the unit for the appropriate operating mode AUTO or LOCAL as shown on pages 5 & 6 respectfully.
7. Apply power to the unit and the green power LED should illuminate to indicate the presence of power.
8. The unit is now ready to be configured using a standard LonWorks tool such as LonMaker or the Safeguard system.



Safeguard Systems

THE DAMPER SPECIALIST COMPANY

Wiring diagram - V3 Control

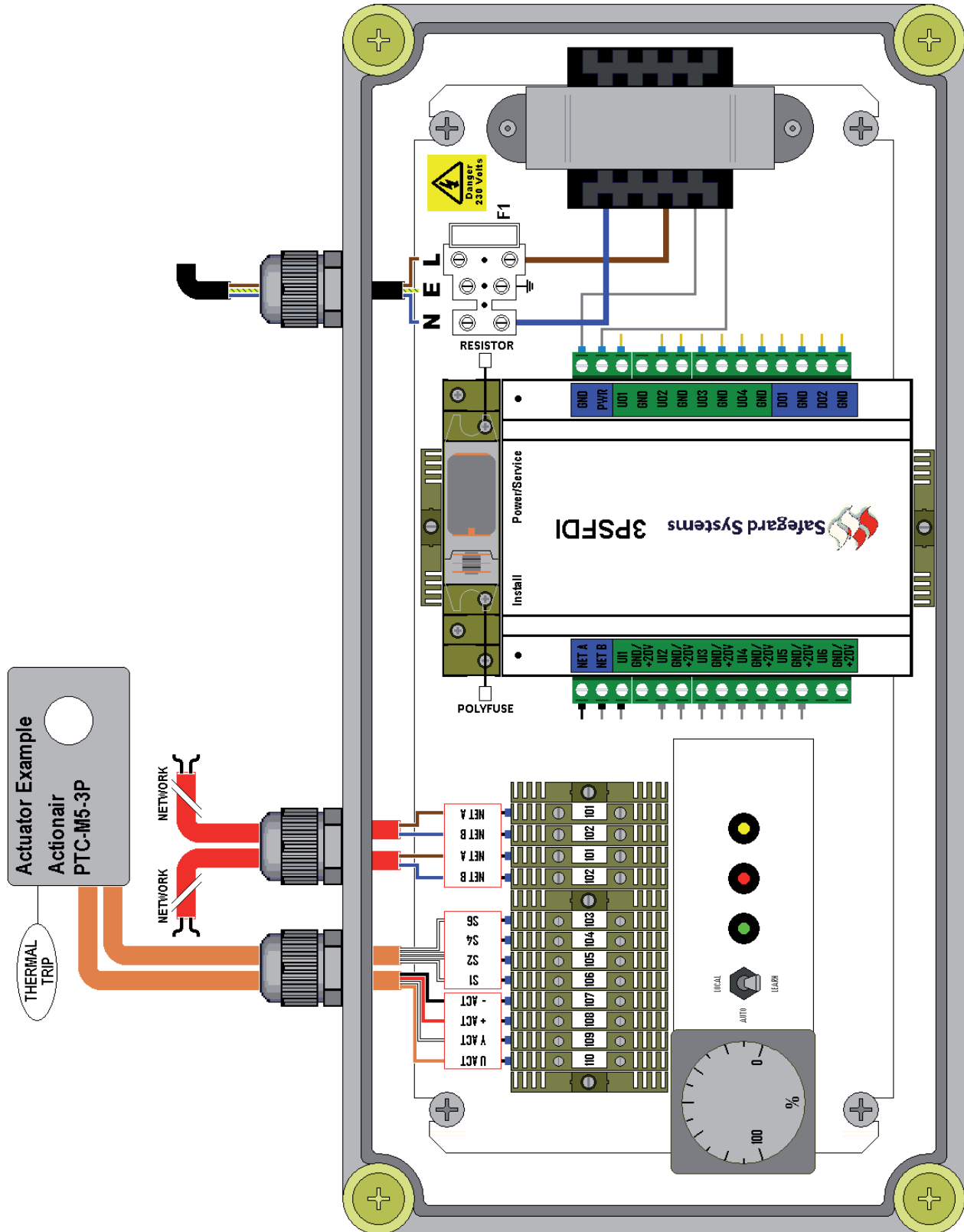



Safeguard Systems

THE DAMPER SPECIALIST COMPANY

Wiring diagram - BMS Control

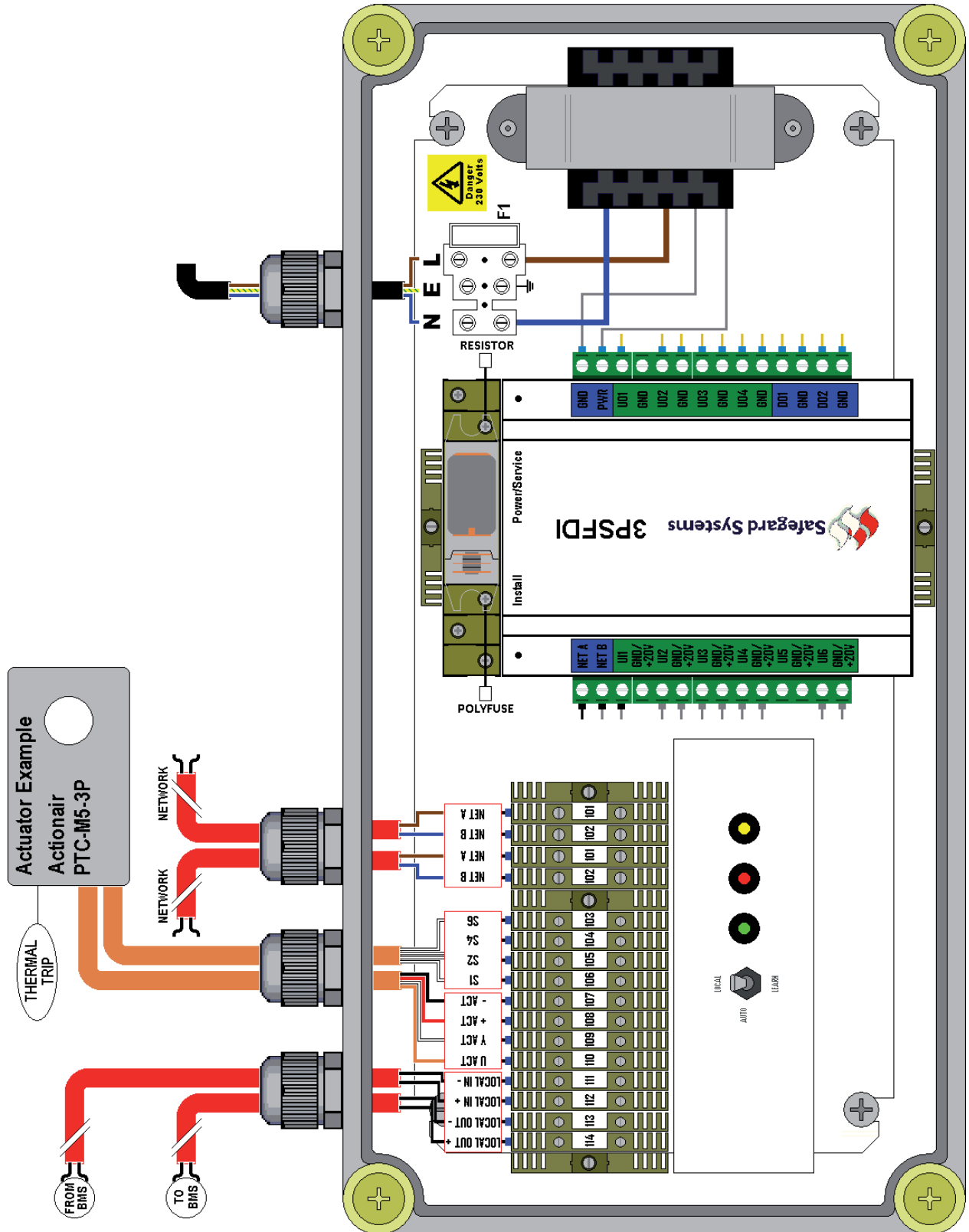



Safeguard Systems

THE DAMPER SPECIALIST COMPANY

Operating Mode: AUTO

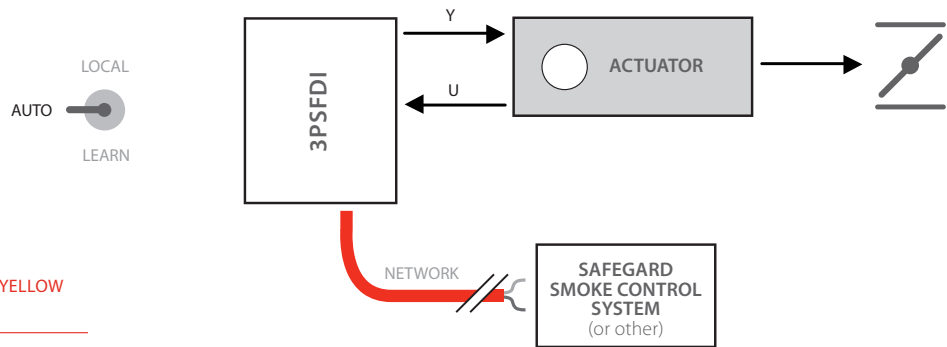

LED Behaviour : AUTO

FUNCTION	GREEN	RED	YELLOW
Open	On	Off	
Closed	Off	On	
Balanced	On	On	
Travelling	Flashing	Flashing	
Fault			Flashing
Offline	On	On	On

Wink function: Service LED (yellow) flashes for 5s

Operating Mode: LEARN

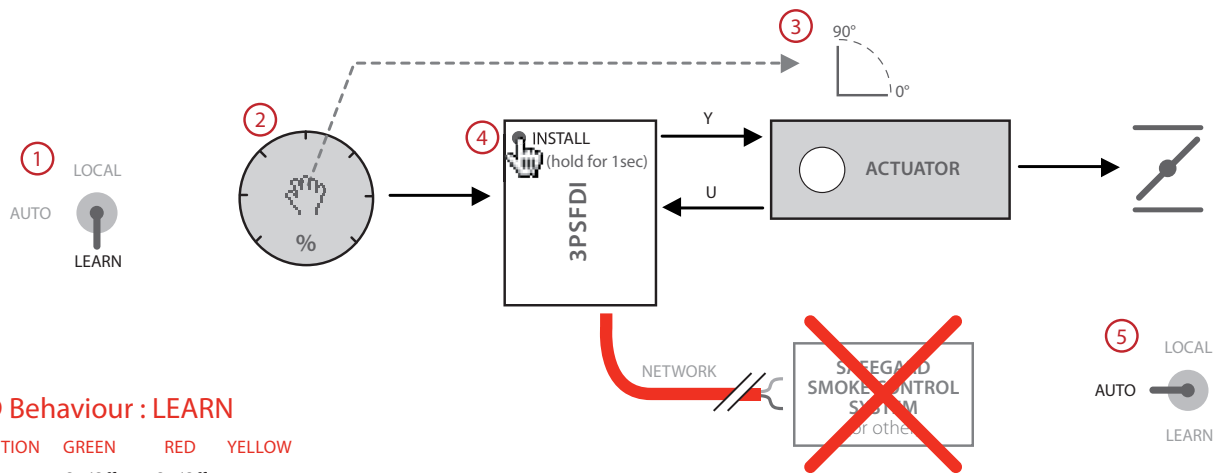

LED Behaviour : LEARN

FUNCTION	GREEN	RED	YELLOW
Learn	On/Off ↔	On/Off	



Operating Mode: LOCAL

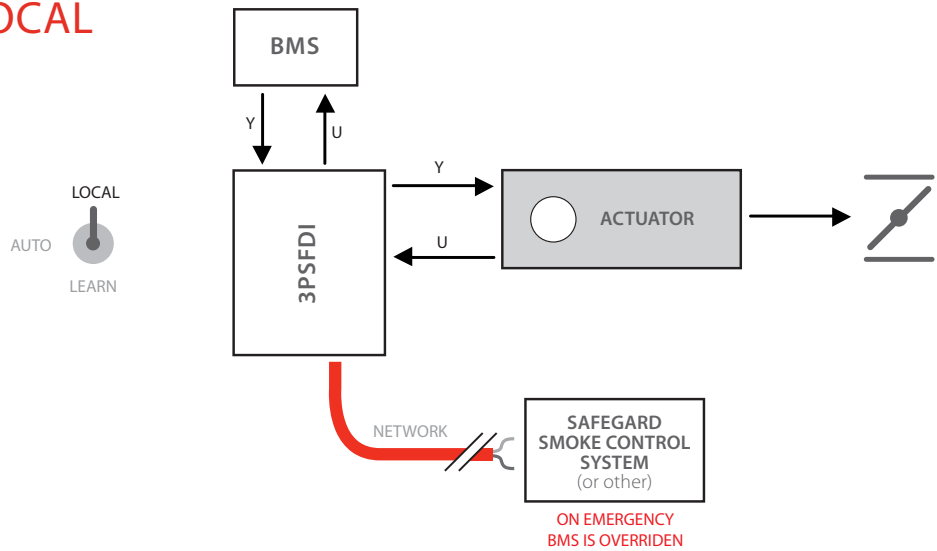

LED Behaviour : LOCAL

FUNCTION	GREEN	RED	YELLOW
Local			On

Maintenance

250mAT 250 VAC (see F1 on wiring diagram)
Suggested replacement: Bussman S504 series.

Terminal Connections

TERMINAL NUMBER	DESCRIPTION
101	NETWORK A
102	NETWORK B
103	ACTUATOR S6
104	ACTUATOR S4
105	ACTUATOR S2
106	ACTUATOR S1
107	ACTUATOR POWER -
108	ACTUATOR POWER +
109	ACTUATOR Y SIGNAL
110	ACTUATOR U SIGNAL
111	LOCAL Y SIGNAL -
112	LOCAL Y SIGNAL +
113	LOCAL U SIGNAL -
114	LOCAL U SIGNAL +



Safeguard Systems

THE DAMPER SPECIALIST COMPANY

Specification

LonWorks

Neuron chip	FT 3150 V13, 20 MHz
Transceiver type	TP/FT-10
Service functions	Service pin, service LED and neuron ID self-adhesive tag

Supply

Input voltage	(230 ± 20) V AC, 50 Hz
Maximum power consumption	10 W

Inputs

*Measuring voltage U	2-10 V DC
----------------------	-----------

Outputs

Maximum load	10 VA at 24 V AC
*Control Signal Y	0-10 V DC

Environmental

Operating temperature	-5 °C to 50 °C
Storage temperature	-20 °C to 50 °C
Humidity	80 % RH to 31 °C decreasing linearly to 50 % RH at 40 °C
Maximum altitude	2000 m

Conformance

EMC	EN 55011: 1999 + A2: 2002 EN 61000-6-1: 2001
LVD	EN 61010-1: 2001

Enclosure

Material	Polycarbonate
IP rating	IP 54
Flammability	UL 94V-0
Pollution	Category 2
Dimensions (excl glands)	378 mm x 188 mm x 130 mm (L x W x D)
Dimensions (incl glands)	378 mm x 213 mm x 130 mm (L x W x D)

*Maximum cable distance 10 m

 Complies with European standards

WARNING: The responsible body shall be made aware that, if the equipment is used in a manner not specified by the manufacturer, the protection provided by the equipment may be impaired.

© 1996 - 2009 Safeguard Systems Limited. The information herein is subject to change without notice. We do not assume any liability arising out of the use of this product. Purchase of goods and services is subject to Safeguard Systems standard terms and conditions. Product warranty 12 months from date of delivery.

LonWorks, LonMark, LonMaker and the 3150 are trademarks of Echelon Corporation registered in the United States and other countries. All other trademarks are acknowledged.



Safeguard Systems
THE DAMPER SPECIALIST COMPANY

Systems House, Unit 34, Southern Cross Business Park, Bray, Co. Wicklow
T: +353 1 2761600 F: +353 1 2761611 E: info@safeguard.ie www.safeguard.ie